

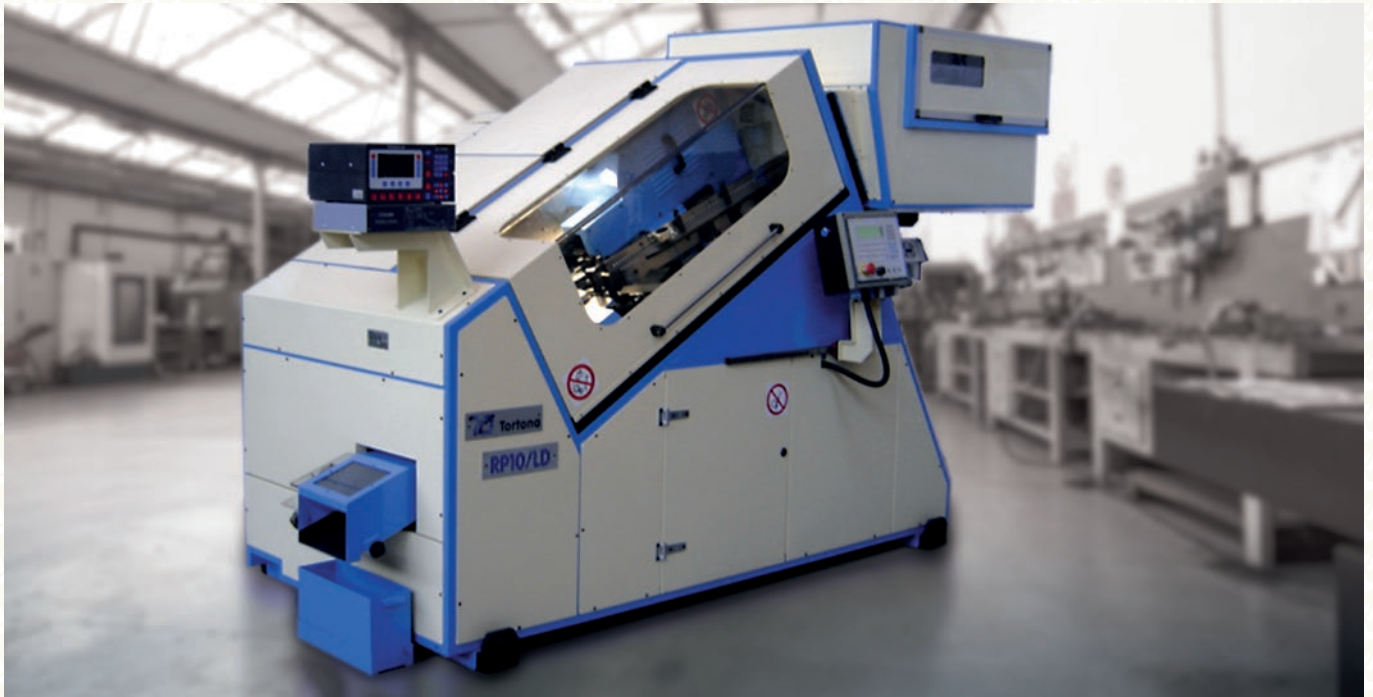

Flat dies machines for screws and special threads

RP10/LD



Dual punch threading machines

Controlled by two slides.

These are defined as dual feeding machines obtained by means of a combination of 2 slides and 1 separator unit with the following functions:

- the separator unit, that closes and supports the screw column,

- the 1st slide, called the positioner, brings the screw to the starting position,
- the 2nd slide, called the feeder, feeds the screw parallel to the rolling dies.

This system prevents overlapping of rivet shanks.

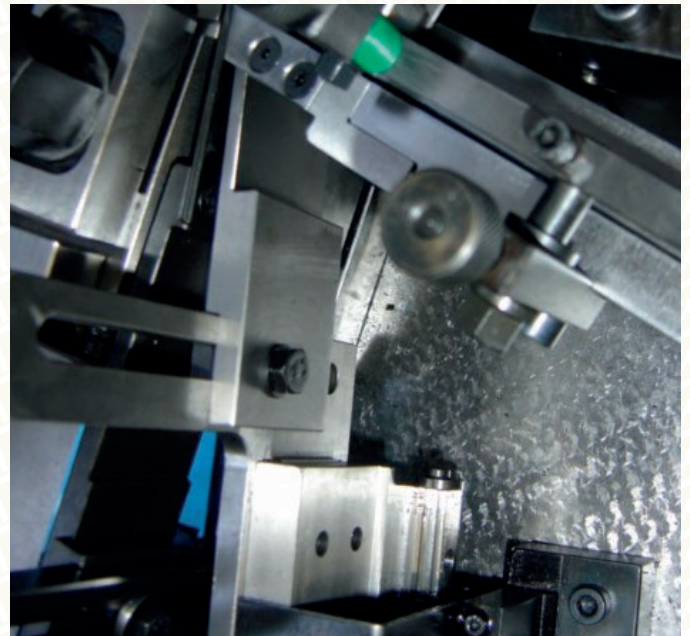
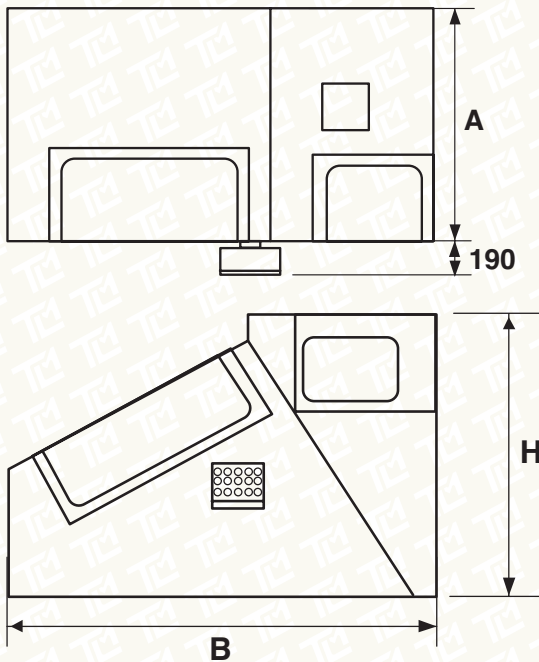

Technical features: approximate values. The machine speed can change according to the material used and the type of item to be rolled. Measures in mm.

Output capacity	Diameter of screw	Length of thread	Max length of shank underhead	Standard tool sizes	Total power of motors	Net weight approx	Machine Sizes	Machine sizes with hood for total soundproofing
min 100 max 320	min 4 max 10	min 15 max 65	130	150x170x80 Sp.35	HP 16	Kg. 3650	2050x1200 x1700	A 1580 – B 2692 H 2070